



Standard cylinder—SC Series

—Tie-rod type

Compendium of SC Series

Standard cylinder manufactured by our enterprise

Bore size: 32, 40, 50, 63, 80, 100

Convenient and fast fix sensor switch

Sensor switch can be directly fixed on the cylinder, which is convenient and fast.
the counterpart sensor switch type is: CMSG、DMSG(S)

Tie-rod cylinder

The cylinder barrel and front/rear cap is jointed by tie rods with high reliability.

Adjustable air buffer

With adjustable air buffer on the front and back cover

Four kinds of cylinder joints

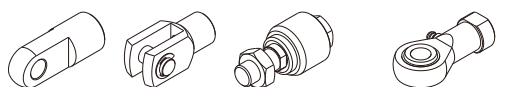

I Knuckle Y Knuckle Floating Joint Universal Joint

Multi-mounting accessories

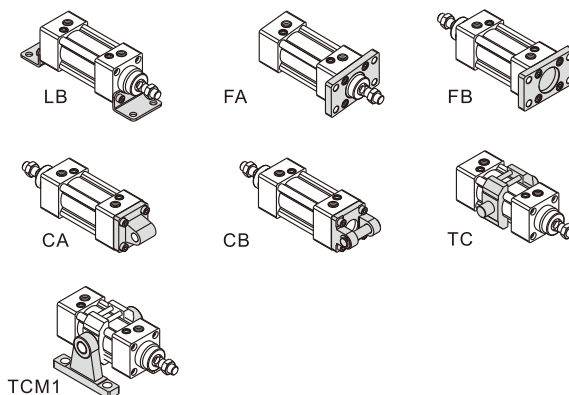

Multi-type cylinder

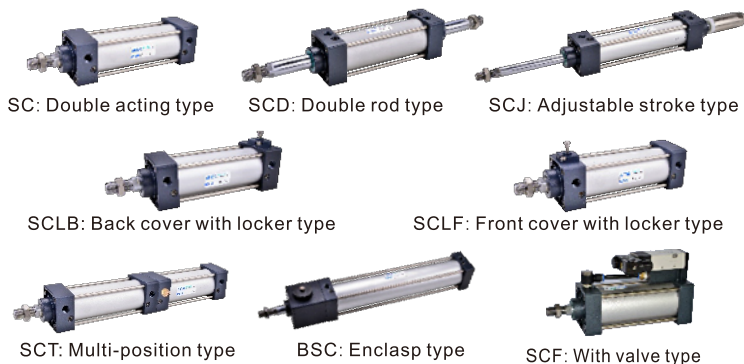

SC: Double acting type SCD: Double rod type SCJ: Adjustable stroke type

SCLB: Back cover with locker type SCLF: Front cover with locker type

SCT: Multi-position type BSC: Enclasp type SCF: With valve type

Criteria for selection: Cylinder thrust

Unit: Newton(N)

Bore size	Rod size	Acting type	Pressure area(mm ²)	Operating pressure(MPa)								
				0.1	0.2	0.3	0.4	0.5	0.6	0.7	0.8	0.9
32	12	Double acting Push side	804	80.4	160.8	241.2	321.6	402.0	482.4	562.8	643.2	723.6
		Pull side	690	69.0	138.0	207.0	276.0	345.0	414.0	483.0	552.0	621.0
40	16	Double acting Push side	1256	125.6	251.2	376.8	502.4	628.0	753.6	879.2	1004.8	1130.4
		Pull side	1055	105.5	211.0	316.5	422.0	527.5	633.0	738.5	844.0	949.5
50	20	Double acting Push side	1963	196.3	392.6	588.9	785.2	981.5	1177.8	1374.1	1570.4	1766.7
		Pull side	1649	164.9	329.8	494.7	659.6	824.5	989.4	1154.3	1319.2	1484.1
63	20	Double acting Push side	3117	311.7	623.4	935.1	1246.8	1558.5	1870.2	2181.9	2493.6	2805.3
		Pull side	2803	280.3	560.6	840.9	1121.2	1401.5	1681.8	1962.1	2242.4	2522.7
80	25	Double acting Push side	5026	502.6	1005.2	1507.8	2010.4	2513.0	3015.6	3518.2	4020.8	4523.4
		Pull side	4536	453.6	907.2	1360.8	1814.4	2268.0	2721.6	3175.2	3628.8	4082.4
100	25	Double acting Push side	7853	785.3	1570.6	2355.9	3141.2	3926.5	4711.8	5497.1	6282.4	7067.7
		Pull side	7362	736.2	1472.4	2208.6	2944.8	3681.0	4417.2	5153.4	5889.6	6625.8
125	32	Double acting Push side	12272	1227.2	2454.4	3681.6	4908.8	6136.0	7363.2	8590.4	9817.6	11044.8
		Pull side	11468	1146.8	2293.6	3440.4	4587.2	5734.0	6880.8	8027.6	9174.4	10321.2
160	40	Double acting Push side	20106	2010.6	4021.2	6031.8	8042.4	10053.0	12063.6	14074.2	16084.8	18095.4
		Pull side	18849	1884.9	3769.8	5654.7	7539.6	9424.5	11309.4	13194.3	15079.2	16964.1
200	40	Double acting Push side	31416	3141.6	6283.2	9424.8	12566.4	15708.0	18849.6	21991.2	25132.8	28274.4
		Pull side	30159	3015.9	6031.8	9047.7	12063.6	15079.5	18095.4	21111.3	24127.2	27143.1
250	50	Double acting Push side	49087	4908.7	9817.4	14726.1	19634.8	24543.5	29452.2	34360.9	39269.6	44178.3
		Pull side	47124	4712.4	9424.8	14137.2	18849.6	23562.0	28274.4	32986.8	37699.2	42411.6

Installation and application



- When load changes in the work, the cylinder with abundant output capacity shall be selected.
- Relative cylinder with high temperature resistance or corrosion resistance shall be chosen under the condition of high temperature or corrosion.
- Necessary protection measure shall be taken in the environment with higher humidity, much dust or water drops, oil dust and welding dregs.
- Dirty substances in the pipe must be eliminated before cylinder is connected with pipeline to prevent the entrance of particles into the cylinder.
- The medium used by cylinder shall be filtered to 40 μm or below.
- Anti-freezing measure shall be adopted under low temperature environment to prevent moisture freezing.
- The cylinder shall be carried out test run without load before application. Prior to run, buffer shall be turned to the minimum and gradually released to avoid the damage on cylinder caused by excessive impact.
- The cylinder shall avoid the influence of side load in operation to maintain the normal work of cylinder and extend the service life.
- If the cylinder is dismantled and stored for a long time, please conduct anti-rust treatment to the surface. Anti-dust caps shall be added in air inlet and outlet ports.

Standard cylinder(Tir-rod)

SC Series

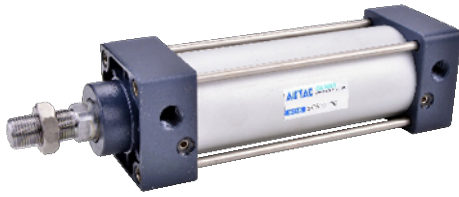

Symbol

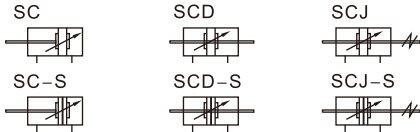

Product feature

- Standard cylinder manufactured by our enterprise.
- The seal of piston adopts heterogeneous two way seal structure. It's dimension is tight and it has the function of grease reservation.
- It is tie rod cylinder. The cylinder barrel and front/rear cap is jointed by tie rods with high reliability.
- Compared with ISO1552 standard cylinder, SC series cylinder with the same bore size is shorter.
- The buffer adjustment of cylinder is smooth and steady.
- Cylinders and mounting accessories with several specifications are optional.
- The seal material with high temperature resistance is adopted to guarantee the normal operation of cylinder at 150℃.

Ordering code

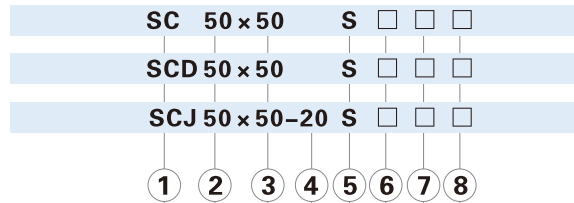

Specification

Bore size(mm)	32	40	50	63	80	100
Acting type	Double acting					
Fluid	Air(to be filtered by 40 μm filter element)					
Mounting type	SC	Basic FA FB CA CB LB TC TCM1				
	SCD、SCJ	Basic FA LB TC TCM1				
Operating pressure	0.15~1.0MPa(22~145psi)(1.5~10.0bar)					
Proof pressure	1.5MPa(215psi)(15bar)					
Temperature ℃	-20~70					
Speed range mm/s	30~800					
Stroke tolerance	0~250 ^{+1.0} ₀ 251~1000 ^{+1.5} ₀ 1001~1500 ^{+2.0} ₀					
Cushion type	Variable cushion					
Adjustable cushion stroke	21 28 29					
Port size [Note1]	1/8"	1/4"	3/8"		1/2"	

[Note1] PT thread, G thread and NPT thread are available.
Add) Refer to P337 for detail of sensor switch.

Stroke

Bore size (mm)	Standard stroke (mm)	Max.std stroke	Max. stroke
32	25 50 75 80 100 125 150 160 175 200 250 300 350 400 450 500	1000	2000
40	25 50 75 80 100 125 150 160 175 200 250 300 350 400 450 500 600 700 800 900 1000	1200	2000
50	25 50 75 80 100 125 150 160 175 200 250 300 350 400 450 500 600 700 800 900 1000	1200	2000
63	25 50 75 80 100 125 150 160 175 200 250 300 350 400 450 500 600 700 800 900 1000	1500	2000
80	25 50 75 80 100 125 150 160 175 200 250 300 350 400 450 500 600 700 800 900 1000	1500	2000
100	25 50 75 80 100 125 150 160 175 200 250 300 350 400 450 500 600 700 800 900 1000	1500	2000

[Note] If the stroke is ≥ 1600mm within the maximum stroke scope, it is treated as non-standard one.
Please contact the company for other special strokes.

① Model	② Bore size	③ Stroke	④ Adjustable stroke	⑤ Magnet	⑥ Mounting type[Note1]	⑦ Seals Material	⑧ Thread type			
SC: Double acting type	32 40 50 63 80 100	Refer to stroke table for details	No this code	Blank: Without magnet S: With magnet	Blank	Blank: TPU H: Viton N: NBR	Blank: PT G: G T: NPT			
SCD: Double rod type										LB
										FA
SCJ: Adjustable stroke type					FB					
					CA					
					CB					
					TC					
					Blank					
					LB					
					FA					
					TC					

[Note1] The accessories are the same as SAU series, please refer to page 48~51 for details; TC is used with TCM1.

Standard cylinder(Tir-rod)

SC Series

Inner structure and material of major parts

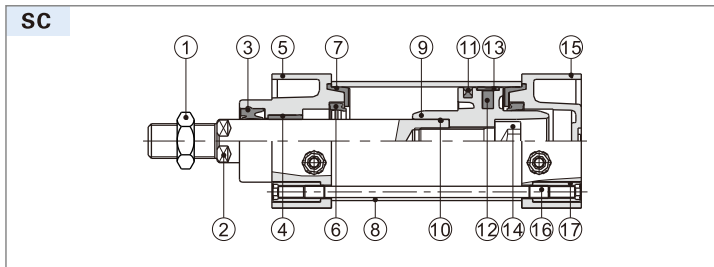

NO.	Item	Material
1	Rod nut	Carbon steel
2	Piston rod	Carbon steel with 20 μm chrome plated
3	Front cover packing	TPU
4	Bushing	Wear resistant material
5	Front cover	Aluminum alloy
6	Cushing O-ring	NBR
7	Cushion gasket	TPU
8	Barrel	Aluminum alloy
9	Piston	Aluminum alloy
10	Piston rod O-ring	NBR
11	Piston seal	NBR
12	Magnet	Plastic
13	Wear ring	Wear resistant material
14	Bolt	Carbon steel
15	Back cover	Aluminum alloy
16	Tie-rod	Carbon steel
17	Tie-rod nut	Carbon steel

Dimensions

SC

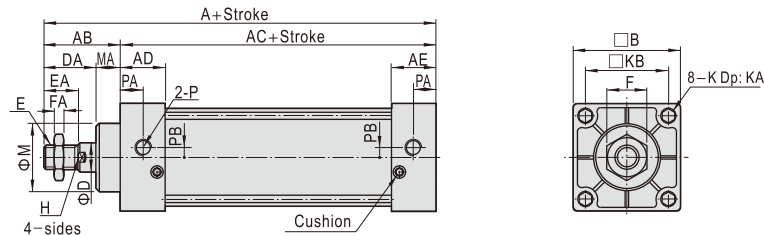

Bore size\Item	A	AB	AC	AD	AE	B	D	DA	E	EA	F	FA	H	K	KA	KB	M	MA	P	PA	PB
32	140	47	93	27.5	27.5	45	12	32	M10×1.25	22	17	6	10	M6×1.0	14.5	33	28	15	1/8"	14	5.5
40	142	49	93	27.5	27.5	50	16	34	M12×1.25	24	17	7	14	M6×1.0	14.5	37	32	15	1/4"	15	6
50	150	57	93	27.5	27.5	62	20	42	M16×1.5	32	23	8	17	M6×1.0	14.5	47	38	15	1/4"	17	8.5
63	153	57	96	27.5	27.5	75	20	42	M16×1.5	32	23	8	17	M8×1.25	14.5	56	38	15	3/8"	15	9.5
80	182	75	107	33	33	94	25	54	M20×1.5	40	26	10	22	M10×1.5	17	70	47	21	3/8"	19.5	10
100	188	75	113	33	33	112	25	54	M20×1.5	40	26	10	22	M10×1.5	17	84	47	21	1/2"	16.5	11

Remark: The dimensions of magnet type cylinder are the same as non-magnet type cylinder.

SCD

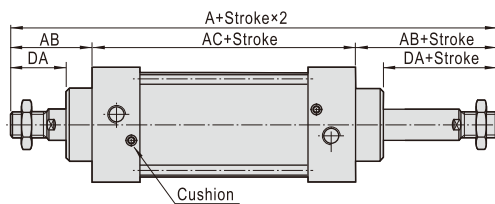

SCJ

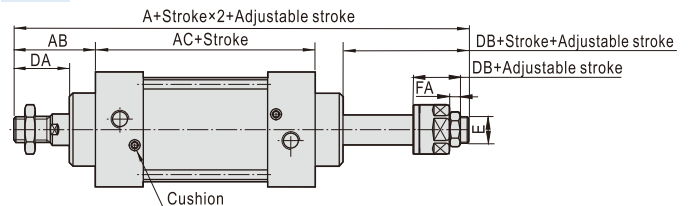

Bore size\Item	A(SCD)	A(SCJ)	AB	AC	DA	DB	E	FA
32	187	182	47	93	32	27	M10X1.25	6
40	191	185	49	93	34	28	M12X1.25	7
50	207	194	57	93	42	29	M16X1.5	8
63	210	197	57	96	42	29	M16X1.5	8
80	257	238.5	75	107	54	35.5	M20X1.5	10
100	263	244.5	75	113	54	35.5	M20X1.5	10

Remark:

- The dimensions of magnet type cylinder are the same as non-magnet type cylinder.
- The unmarked dimension is the same as SC standard type.

Standard cylinder(Tir-rod)

SC Series——Big bore size type



Symbol

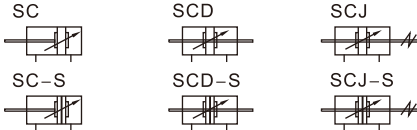

Product feature

- ISO6430 standard cylinder.
- The seal of piston adopts heterogeneous two way seal structure. It's dimension is tight and it has the function of grease reservation.
- It is tie rod cylinder. The cylinder barrel and front/rear cap is jointed by tie rods with high reliability.
- Compared with ISO15552 standard cylinder, SC series cylinder with the same bore size is shorter.
- The buffer adjustment of cylinder is smooth and steady.
- Cylinders and mounting accessories with several specifications are optional.
- The seal material with high temperature resistance is adopted to guarantee the normal operation of cylinder at 150℃.

Specification

Bore size(mm)	125	160	200	250
Acting type	Double acting			
Fluid	Air(to be filtered by 40 μ m filter element)			
Mounting type	SC	Basic FA FB CA CB LB TC TCM1		
	SCD、SCJ	Basic FA LB TC TCM1		
Operating pressure	0.15~1.0MPa(22~145psi)(1.5~10.0bar)			
Proof pressure	1.5MPa(215psi)(15bar)			
Temperature ℃	-20~70			
Speed range mm/s	30~800			
Stroke tolerance	0~250 ^{+1.0} ₀ 251~1000 ^{+1.5} ₀ 1001~1500 ^{+2.0} ₀			
Cushion type	Variable cushion			
Adjustable cushion stroke	28	29	33	40
Port size [Note1]	1/2"	3/4"		1"

[Note1] PT thread, G thread and NPT thread are available.
Add) Refer to P337 for detail of sensor switch.

Stroke

Bore size (mm)	Standard stroke (mm)																Max.std stroke	Max. stroke					
125	25	50	75	80	100	125	150	160	175	200	250	300	350	400	450	500	600	700	800	900	1000	1500	2000
160	25	50	75	80	100	125	150	160	175	200	250	300	350	400	450	500	600	700	800	900	1000	1500	2000
200	25	50	75	80	100	125	150	160	175	200	250	300	350	400	450	500	600	700	800	900	1000	1500	2000
250	25	50	75	80	100	125	150	160	175	200	250	300	350	400	450	500	600	700	800	900	1000	1500	2000

[Note] Please contact the company for other special strokes.

Ordering code

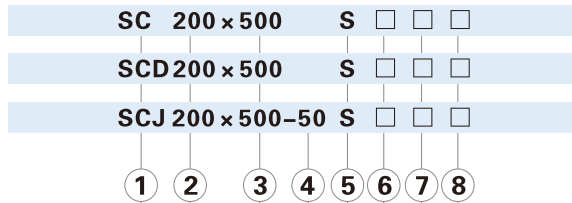

① Model	② Bore size	③ Stroke	④ Adjustable stroke	⑤ Magnet	⑥ Mounting type[Note1]	⑦ Seals Material	⑧ Thread type
SC: Double acting type	125 160 200 250	Refer to stroke table for details	No this code	Blank: Without magnet S: With magnet	Blank	Blank: NBR H: Viton	Blank: PT G: G T: NPT
SCD: Double rod type					LB		
SCJ: Adjustable stroke type					FA		
			10 20 30 40 50 75 100		FB		
					CA		
					CB		
					TC		
					Blank		
					LB		
					FA		
					TC		

[Note1] Please refer to page 48~51 for accessory parts.TC is used with TCM1.

Standard cylinder(Tir-rod)

SC Series—Big bore size type

Inner structure and material of major parts

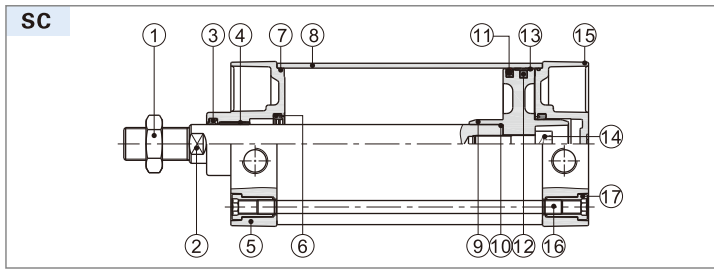

NO.	Item	Material
1	Rod nut	Carbon steel
2	Piston rod	Carbon steel with 20 μ m chrome plated
3	Front cover packing	TPU
4	Bushing	Wear resistant material
5	Front cover	Aluminum alloy
6	Cushioning O-ring	TPU
7	O-ring	NBR
8	Barrel	Aluminum alloy
9	Piston	Aluminum alloy
10	Piston rod O-ring	NBR
11	Piston seal	NBR
12	Magnet	Plastic
13	Wear ring	Wear resistant material
14	Bolt	Carbon steel
15	Back cover	Aluminum alloy
16	Tie-rod	Carbon steel
17	Tie-rod nut	Carbon steel

Dimensions

SC

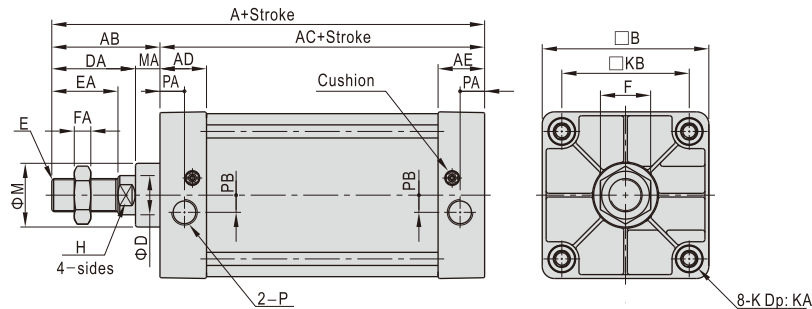

Bore size\Item	A	AB	AC	AD	AE	B	D	DA	E	EA	F	FA	H	K	KA	KB	M	MA	P	PA	PB
125	203	88	115	38	38	136	32	68	M27×2.0	54	41	13.5	27	M12×1.75	21	104	52	20	1/2"	20	14
160	239	113	126	38	38	174	40	88	M36×2.0	72	55	18	36	M16×2.0	21	134	62	25	3/4"	20	15
200	244	118	126	38	38	214	40	88	M36×2.0	72	55	18	36	M16×2.0	21	163	62	30	3/4"	20	15
250	294	141	153	48	48	267	50	106	M42×2.0	84	65	21	46	M20×2.5	26	202	86	35	1"	25.5	22

Remark: The dimensions of magnet type cylinder are the same as non-magnet type cylinder.

SCD

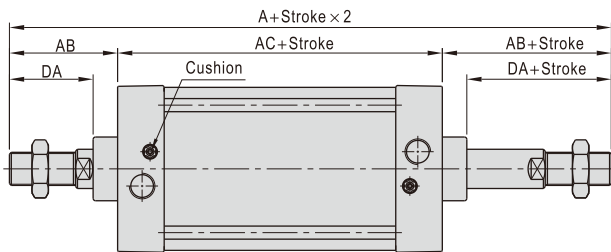

SCJ

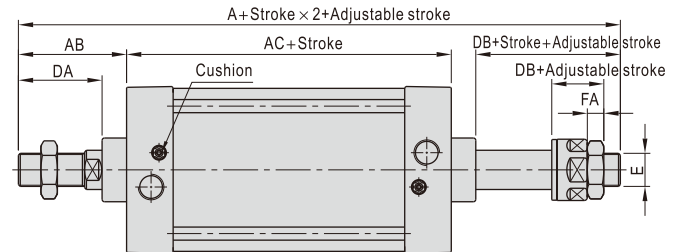

Bore size\Item	A(SCD)	A(SCJ)	AB	AC	DA	DB	E	FA
125	291	265.5	88	115	68	42.5	M27X2.0	13.5
160	352	332	113	126	88	68	M36X2.0	18
200	362	342	118	126	88	68	M36X2.0	18
250	435	409	141	153	106	80	M42X2.0	21

Remark:

1. The dimensions of magnet type cylinder are the same as non-magnet type cylinder.
2. The unmarked dimension is the same as SC standard type.

Standard cylinder(Tie-rod)

SCT Series—Multi-position type



Symbol



Specification

Bore size(mm)	32	40	50	63	80	100
Acting type	Double acting					
Fluid	Air(to be filtered by 40 μm filter element)					
Mounting type	Basic FA FB CA CB LB TC TCM1					
Operating pressure	0.15~1.0MPa(22~145psi)(1.5~10.0bar)					
Proof pressure	1.5MPa(215psi)(15bar)					
Temperature °C	-20~70					
Speed range mm/s	30~800					
Stroke tolerance	0~250 ^{+1.0} ₀ 251~1000 ^{+1.5} ₀ 1001~1500 ^{+2.0} ₀					
Cushion type	Variable cushion					
Adjustable cushion stroke	21		28		29	
Port size [Note1]	1/8"	1/4"	3/8"		1/2"	

[Note1] PT thread, G thread and NPT thread are available.
Add) Refer to P337 for detail of sensor switch.

Product feature

- Standard cylinder manufactured by our enterprise.
- The seal of piston adopts heterogeneous two way seal structure. It's dimension is tight and it has the function of grease reservation.
- It is tie rod cylinder. The cylinder barrel and front/rear cap is jointed by tie rods with high reliability.
- Piston rod can be positioned in several positions in the whole action process.

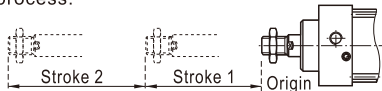

- The buffer adjustment of cylinder is smooth and steady.
- Cylinders and mounting accessories with several specifications are optional.
- The seal material with high temperature resistance is adopted to guarantee the normal operation of cylinder at 150°C.

Stroke

Bore size (mm)	Standard stroke (mm)															Max.std stroke	Max. stroke	
	25	50	75	80	100	125	150	160	175	200	250	300	350	400	450			500
32	25	50	75	80	100	125	150	160	175	200	250	300	350	400	450	500	500	800
40	25	50	75	80	100	125	150	160	175	200	250	300	350	400	450	500	500	800
50	25	50	75	80	100	125	150	160	175	200	250	300	350	400	450	500	500	800
63	25	50	75	80	100	125	150	160	175	200	250	300	350	400	450	500	500	800
80	25	50	75	80	100	125	150	160	175	200	250	300	350	400	450	500	500	800
100	25	50	75	80	100	125	150	160	175	200	250	300	350	400	450	500	500	800

[Note] If the stroke is ≥800mm within the maximum stroke scope, it is treated as non-standard one.
Please contact the company for other special strokes.

Ordering code

SCT 50 × 50 × 50 S □ □ □



① Model	② Bore size	③ Stroke 1	④ Stroke 2	⑤ Magnet	⑥ Mounting type[Note1]	⑦ Seals Material	⑧ Thread type
SCT: Double acting Multi-position type	32 40 50 63 80 100	Refer to stroke table for details	Refer to stroke table for details	Blank: Without magnet S: With magnet	Blank	Blank: TPU H: Viton N: NBR	Blank: PT G: G T: NPT
					LB		
					FA		
					FB		
					CA		
					CB		
					TC		

[Note1] Please refer to page 48~51 for accessory parts. TC is used with TCM1.

Standard cylinder(Tir-rod)

SCT Series—Multi-position type

Inner structure and material of major parts

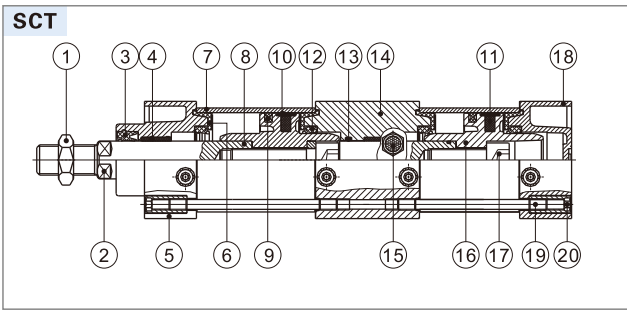

NO.	Item	Material	NO.	Item	Material
1	Rod nut	Carbon steel	11	Magnet	Plastic
2	Piston rod	Carbon steel with 20 μ m chrome plated	12	Gasket	NBR
			13	O-ring	NBR
3	Packing	TPU	14	Joint seat	Aluminum alloy
4	Bushing	Wear resistant material	15	Silencer	
5	Front cover	Aluminum alloy	16	Piston	Aluminum alloy
6	Cushing O-ring	TPU	17	Bolt	Carbon steel
7	Barrel	Aluminum alloy	18	Back cover	Aluminum alloy
8	Rod O-ring	NBR	19	Tie-rod	Carbon steel
9	Piston seal	NBR	20	Tie-rod nut	Carbon steel
10	Wear ring	Wear resistant material			

Dimensions

SCT

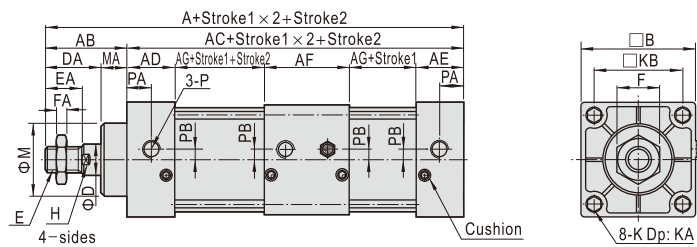

Bore size\Item	A	AB	AC	AD	AE	AF	AG	B	D	DA	E	EA	F	FA	H	K	KA	KB	M	MA	P	PA	PB
32	233	47	186	27.5	27.5	55	38	45	12	32	M10×1.25	22	17	6	10	M6×1.0	14.5	33	28	15	1/8"	14	5.5
40	235	49	186	27.5	27.5	55	38	50	16	34	M12×1.25	24	17	7	14	M6×1.0	14.5	37	32	15	1/4"	15	6
50	243	57	186	27.5	27.5	55	38	62	20	42	M16×1.5	32	23	8	17	M6×1.0	14.5	47	38	15	1/4"	17	8.5
63	249	57	192	27.5	27.5	55	41	75	20	42	M16×1.5	32	23	8	17	M8×1.25	14.5	56	38	15	3/8"	15	9.5
80	296	75	221	33	33	73	41	94	25	54	M20×1.5	40	26	10	22	M10×1.5	17	70	47	21	3/8"	19.5	10
100	308	75	233	33	33	73	47	112	25	54	M20×1.5	40	26	10	22	M10×1.5	17	84	47	21	1/2"	16.5	11

Remark: The dimensions of magnet type cylinder are the same as non-magnet type cylinder.

Standard cylinder(Tir-rod)

SCL Series—With locker type



Symbol



Product feature

1. With lock cylinder: front cover with lock type and rear cover lock type;
2. The way of unlocking: automatic and manual.

Specification

Bore size(mm)	40	50	63	80	100
Acting type	Double acting				
Fluid	Air(to be filtered by 40 μm filter element)				
Mounting type	Basic FA FB CA CB LB TC TCM1				
Operating pressure	0.15~1.0MPa(22~145psi)(1.5~10.0bar)				
Proof pressure	1.5MPa(215psi)(15bar)				
Temperature °C	-20~70				
Speed range mm/s	30~800				
Stroke tolerance	0~250 ^{+1.0} ₀	251~1000 ^{+1.5} ₀	1001~1500 ^{+2.0} ₀		
Cushion type	Variable cushion				
Adjustable cushion stroke	No locker end		24		32
	With locker end		13.5		15
Port size [Note1]	1/4"		3/8"		1/2"

[Note1] PT thread, G thread and NPT thread are available.
Add) Refer to P337 for detail of sensor switch.

Stroke

Bore size (mm)	Standard stroke (mm)	Max.std stroke	Max. stroke
40	25 50 75 80 100 125 150 160 175 200 250 300 350 400 450 500 600 700 800	1200	1800
50	25 50 75 80 100 125 150 160 175 200 250 300 350 400 450 500 600 700 800 900 1000	1200	1800
63	25 50 75 80 100 125 150 160 175 200 250 300 350 400 450 500 600 700 800 900 1000	1500	1800
80	25 50 75 80 100 125 150 160 175 200 250 300 350 400 450 500 600 700 800 900 1000	1500	1800
100	25 50 75 80 100 125 150 160 175 200 250 300 350 400 450 500 600 700 800 900 1000	1500	1800

[Note] Please contact the company for other special strokes.

Ordering code

SCL B 50 × 50 S □ □



① Model	② Locker position	③ Bore size	④ Stroke	⑤ 磁石代號	⑥ Mounting type[Note1]	⑦ Thread type
SCL: Double acting type (with locker)	B: Back cover with locker F: Front cover with locker	40 50 63 80 100	Refer to stroke table for details	Blank: Without magnet S: With magnet	Blank LB FA FB CA CB TC	Blank: PT G: G T: NPT

[Note1] The accessories are the same as SAU series, please refer to page 48~51 for details; TC is used with TCM1.

Inner structure and material of major parts

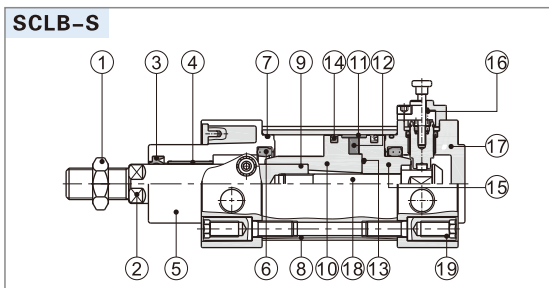

NO.	Item	Material	NO.	Item	Material
1	Rod nut	Carbon steel	10	Magnet holder	Aluminum alloy
2	Piston rod	Carbon steel with 20μm chrome plated	11	Wear ring	Wear resistant material
3	Front cover packing	NBR	12	Magnet	Plastic
4	Bushing	Wear resistant material	13	O-ring	NBR
5	Front cover	Aluminum alloy	14	Piston Seal	BNR
6	Cushing O-ring	NBR	15	Guilder holder	Aluminum alloy
7	O-ring	NBR	16	Locker	
8	Barrel	Aluminum alloy	17	Back cover	Aluminum alloy
9	O-ring	NBR	18	Bolt	Carbon steel
			19	Tie-rod nut	Carbon steel

Standard cylinder(Tir-rod)

SCL Series—With locker type

Dimensions

SCLB

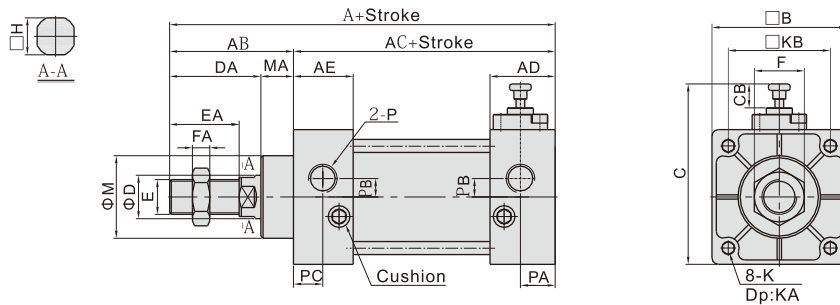

SCLF

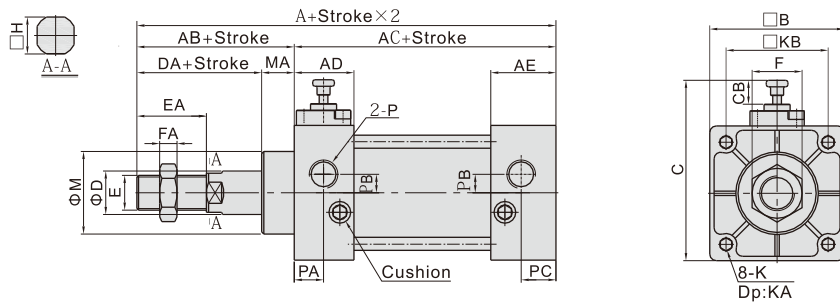

Bore size\Item	A	AB	AC	AD	AE	B	C	CB	D	DA	E	EA	F	FA	H	K	KA	KB	M	MA	P	PA	PB	PC
40	144.5	49	95.5	30	27.5	50	71	10	16	34	M12×1.25	24	17	7	14	M6×1.0	14.5	37	32	15	1/4"	16	6	13.5
50	152.5	57	95.5	30	27.5	62	83	10	20	42	M16×1.5	32	23	8	17	M6×1.0	14.5	47	38	15	1/4"	16	8.5	13.5
63	157	57	100	31.5	27.5	75	96	8	20	42	M16×1.5	32	23	8	17	M8×1.25	14.5	56	38	15	3/8"	16.5	7	13.5
80	188	75	113	39	33	94	116	8	25	54	M20×1.5	40	26	10	22	M10×1.5	17	70	47	21	3/8"	19	10	16.5
100	194	75	119	39	33	112	134	8	25	54	M20×1.5	40	26	10	22	M10×1.5	17	84	47	21	1/2"	19	11	16.5

Remark: The dimensions of magnet type cylinder are the same as non-magnet type cylinder.

Use and maintenance

- Under the condition of locking, there is a great danger to the gas port A when there is no pressure on both sides of the air port. There is a great danger similar to the release of locking, or the sudden release of lock and the piston rod flying. When the locking mechanism is lifted, it is necessary to supply the pressure of the air inlet B and remove the lock mechanism without load.
- If the fast exhaust valve is used to speed down the drop speed, the cylinder phenomenon is sometimes started than the lock pin first and can not be removed normally. Therefore, please do not use the fast exhaust valve with the lock cylinder.
- Please do not use three solenoid valves: please do not combine with three (especially the seal type metal seal) solenoid valve. If pressure is sealed in the air inlet with the locking mechanism side, the lock will not work. In addition, even if it is temporarily locked, the air leaked from the solenoid valve will enter the cylinder, and the lock will be lifted after a period of time.
- If the locking mechanism side bears the back pressure, sometimes the lock will be lifted, so please use a single or integrated individual exhaust type solenoid valve.
- If the cylinder with adjustable cushioning is excessive, if the air cushion valve needle on the locking mechanism side is screwed too much, the piston will sometimes cause restraint at the stroke terminal, causing the damage of the locking mechanism. Therefore, the needle valve should be adjusted to make the piston not be restrained.
- When the manual operation of the locking mechanism is completed, it is necessary to reset the manual device to the in situ. In addition, please do not do manual operation outside the adjustment, otherwise it will be more dangerous.
- When the cylinder is installed and adjusted, please dissolve the lock: in the lock state of the installation and other operations, sometimes it causes the lock-in parts to be damaged.
- Please do not use multiple cylinders at the same time: please do not use more than 2 locking cylinders at the same time to drive a workpiece. Sometimes one of the cylinders will not be locked out.
- Please use the speed control valve in the exhaust throttle control state: in the intake throttling control, it is sometimes impossible to release the lock.
- In the lock side, please be sure to use the terminal of the cylinder stroke: if the piston of the cylinder does not reach the terminal, locking will fail or lock.
- Manual operation is a non locking way to release: pull the lever into the anti falling piston, and pull the bolt out of the 4mm with the force of more than 20N. After the piston is moved away, it can release the lock. (no load level installation or opposite side port pressurization), or after loosened, the anti falling piston returns to the original position through the action of the stop spring and enters the piston rod groove, and the piston becomes locked.

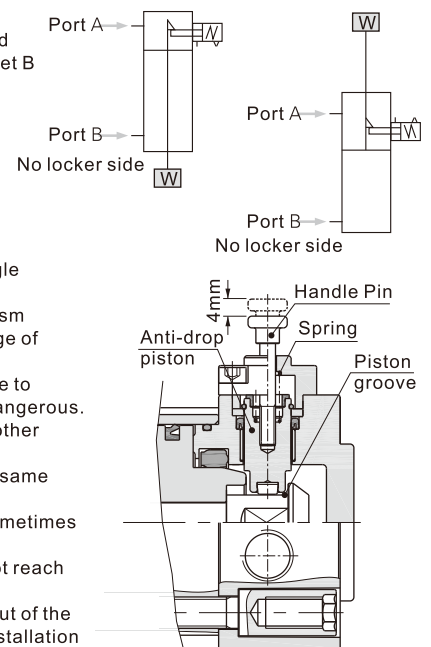

Standard cylinder(Tir-rod)

SCF Series—With valve type



Symbol

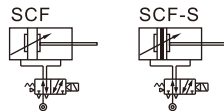

Product feature

1. For Standard Cylinders: use 4M210 valve for bore size 32, 40 & 50; 4M310 valve for bore size 63, 80 & 100mm.
2. Individually control, no need for extra solenoid valves.
3. Installation time & space saving; suitable for decentralize installation in large system.
4. Options of mounting accessories & easy installation.

Stroke

Bore size(mm)	Standard stroke (mm)	Mini. stroke	Max. std	Max. stroke
32	Standard type 50 75 80 100 125 150 160 175 200 250 300 350 400 450 500	50	1000	2000
	With TC type 100 125 150 160 175 200 250 300 350 400 450 500	100		
40	Standard type 50 75 80 100 125 150 160 175 200 250 300 350 400 450 500 600 700 800 900 1000	50	1200	2000
	With TC type 100 125 150 160 175 200 250 300 350 400 450 500 600 700 800 900 1000	100		
63	Standard type 75 80 100 125 150 160 175 200 250 300 350 400 450 500 600 700 800 900 1000	75	1500	2000
	With TC type 125 150 160 175 200 250 300 350 400 450 500 600 700 800 900 1000	125		

[Note] Consult us for non-standard stroke.

Specification

Cylinder specification						
Bore size(mm)	32	40	50	63	80	100
Acting type	Double acting					
Fluid	Air(to be filtered by 40 μm filter element)					
Mounting type	Basic FA FB CA CB LB TC TCM1					
Operating pressure	0.1~1.0MPa(15~145psi)(1.0~10.0bar)					
Proof pressure	1.5MPa(215psi)(15bar)					
Temperature °C	-20~70					
Speed range mm/s	30~800					
Stroke tolerance	0~250 ^{+1.0} ₀		251~1000 ^{+1.5} ₀		1001~1500 ^{+2.0} ₀	
Cushion type	Variable cushion					
Adjustable cushionstroke	21		28		29	
Port size	1/8"	1/4"	3/8"		1/2"	
PU tube size(ODXID)	φ8 × φ5			φ10 × φ6.5		
Solenoid valve specification						
Model	4M210-06 & 4M210-08		4M310-08 & 4M310-10			
Fluid	Air(to be filtered by 40 μm filter element)					
Acting type	Internal piloted					
Port size [Note1]	In=Exhaust=1/8" & In=1/4" Exhaust=1/8"			In=Exhaust=1/4" & In=PT3/8 Exhaust=1/4"		
Orifice size	4M210-06: 14.0mm ² (Cv=0.78) 4M210-08: 16.0mm ² (Cv=0.89)		4M310-08: 25.0mm ² (Cv=1.40) 4M310-10: 30.0mm ² (Cv=1.68)			
Valve type	5 port 2 position					
Operating pressure	0.15~0.8MPa(21~114psi)					
Proof pressure	1.5MPa(215psi)					
Temperature °C	-20~70					
Body material	Aluminum alloy					
Lubrication [Note2]	Not required					
Max. frequency [Note3]	5 cycle/sec			4 cycle/sec		
Coil specification						
Standard voltage	AC220V、AC110V、AC24V、DC24V、DC12V					
Scope voltage	AC: ±15% DC: ±10%					
Power consumption	AC: 3.5VA DC: 3.0W					
Protection	IP65(DIN40050)					
Temperature classification	B Class					
Electrical entry	Terminal, Grommet					
Activating time	0.05 sec and below					

[Note1] PT thread, G thread and NPT thread are available.

[Note2] It can't stop in the midway of lubricating. Lubricants like ISO VG32 or equivalent are recommended.

[Note3] The maximum actuation frequency is in the no-load state.
Add) Refer to P337 for detail of sensor switch.

Ordering code

SCF 50 × 1000 S □ -06 A □ □

① ② ③ ④ ⑤ ⑥ ⑦ ⑧ ⑨

① Model	② Bore size	③ Stroke	④ Magnet	⑤ Mounting type[Note1]	⑥ Port size	⑦ Voltage	⑧ Electrical entry	⑨ Thread type
SCF: Double acting with valve type	32 40 50 63 80 100	Refer to stroke table for details	Blank: Without magnet S: With magnet	Blank	06: 1/8" 08: 1/4" 10: 3/8"	A: AC220V B: DC24V C: AC110V E: AC24V F: DC12V	Blank: Terminal I: Grommet	Blank: PT G: G T: NPT
				LB				
				FA				
				FB				
				CA				
				CB				
				TC				

[Note1] Please refer to page 48~51 for accessory parts. TC is used with TCM1.

Standard cylinder(Tir-rod)

SCF Series—With valve type

Inner structure

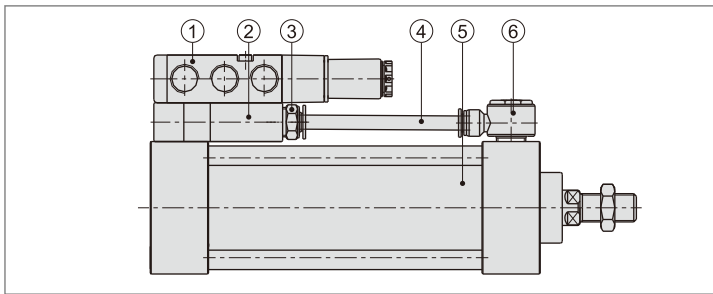

NO.	Item
1	4M series solenoid valve
2	Unite block
3	APC series tube connector
4	PU tube
5	SC series cylinder
6	APH series tube connector

Dimensions

Pull when energized

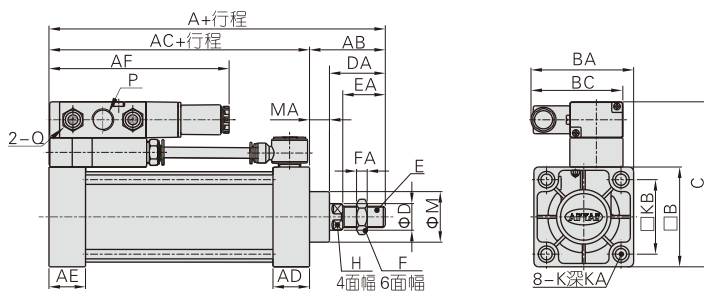

Push when energized

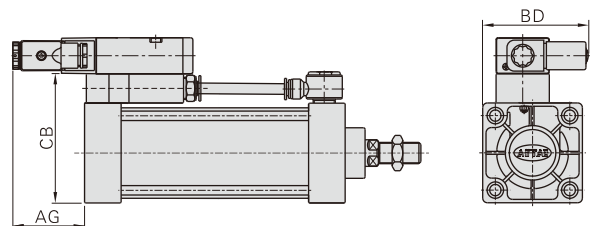

Bore size\Item	A	AB	AC	AD	AE	AF	AG	B	BA	BC	BD
32	140	47	93	27.5	27.5	118	53	45	67	67	77
40	142	49	93	27.5	27.5	118	53	50	68.5	67	80.5
50	150	57	93	27.5	27.5	120	51	62	72	67	89
63	153	57	96	27.5	27.5	135.5	54.5	75	77.5	69.5	96.5
80	182	75	107	33	33	137	53	94	86.5	69.5	106.5
100	188	75	113	33	33	135.5	54.5	112	96	69.5	115

Bore size\Item	C	CB	D	DA	E	EA	F	FA	M	MA
32	89	67	12	32	M10X1.25	22	17	6	28	15
40	94	72	16	34	M12X1.25	24	17	7	32	15
50	106	84	20	42	M16X1.5	32	23	8	38	15
63	124	97	20	42	M16X1.5	32	23	8	38	15
80	143	116	25	54	M20X1.5	40	26	10	47	21
100	161	134	25	54	M20X1.5	40	26	10	47	21

Bore size\Item	Compatible valve's type	P	Q	K	KA	KB	H
32	4M210-06	1/8"	1/8"	M6X1	14.5	33	10
	4M210-08	1/4"					
40	4M210-06	1/8"	1/8"	M6X1	14.5	37	14
	4M210-08	1/4"					
50	4M210-06	1/8"	1/8"	M6X1	14.5	47	17
	4M210-08	1/4"					
63	4M310-08	1/4"	1/4"	M8X1.25	14.5	56	17
	4M310-10	3/8"					
80	4M310-08	1/4"	1/4"	M10X1.5	17	70	22
	4M310-10	3/8"					
100	4M310-08	1/4"	1/4"	M10X1.5	17	84	22
	4M310-10	3/8"					

Remark: The dimensions of magnet type cylinder are the same as non-magnet type cylinder.

How to use

- Options for piston rod to retract or extend when solenoid coil is energized.
- Default factory setting will be piston rod to retract when energized(see Drawing one). Should you require piston rod to extend when energized, reposition the solenoid valve as shown in Drawing two.

Drawing one

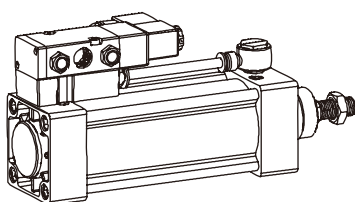

Pull when energized

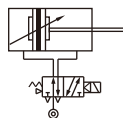

Drawing two

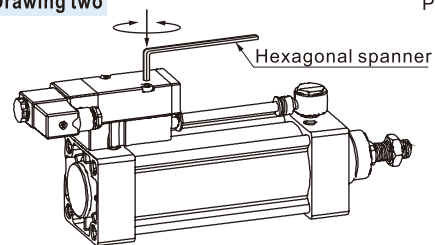

Push when energized

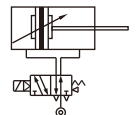

Attention Ensure that the seals between the mounting block & valve are placed correctly when repositioning the valve.



Enclasp cylinder——BSC Series

——Tie-rod type

Compendium of BSC Series

Spring and gripper patch enclasp equipment

Simplicity structure
Celerity and availability locked or unlocked
State switch steadily

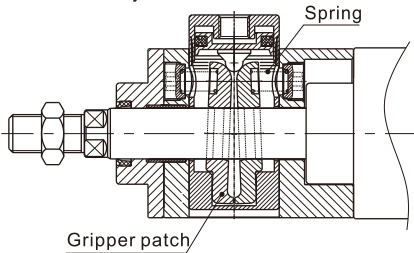

Multi-kinds unlocked mode

Air pressure unlocked mode and manual unlocked mode are available

Air pressure unlocked mode

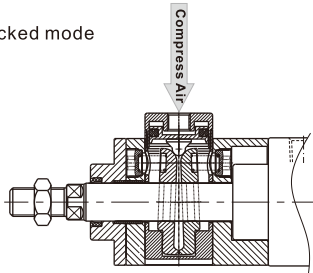

Manual unlocked screw

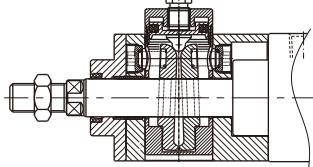

Compact enclasp equipment

Compact enclasp equipment to save space

Multi-type cylinder and bore size

BSC, BSCD type available

Bore size: 32、40、50、63、80、100、125

How to mount and use

1. The locker equipment only be locked after cylinder stopped, can't brake the piston rod while it is moving. If the lock cylinder be used for control system with safety demand, other safety measure is required.
2. The locker equipment only be unlocked when the air pressure on both sides of piston rod are equation or the cylinder stopped, otherwise piston rod movies abruptly might produce accident.
3. Typical applications

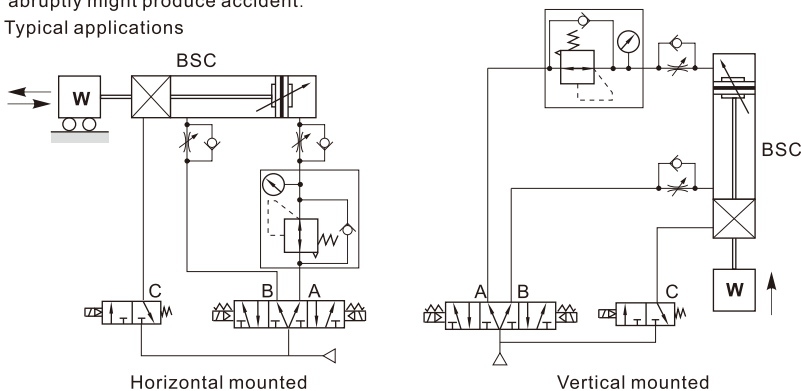

Acting type

Yes or No inlet			State of acting
A Port	B Port	C Port	
Yes	No	Yes	Advance
Yes	Yes	No	Locked
Yes	Yes	Yes	unlocked
Yes	No	Yes	Advance to rod protruded completely
No	Yes	Yes	Back
Yes	Yes	No	Locked
Yes	Yes	Yes	unlocked
No	Yes	Yes	back to rod retracted completely

Over 0.5S

0~0.5S

Over 0.5S

0~0.5S

Circle

Standard cylinder(Tir-rod)

BSC Series—Enclasp type



Specification

Bore size(mm)	32	40	50	63	80	100	125
Acting type	Double acting						
Fluid	Air(to be filtered by 40 μm filter element)						
Mounting type	BSC	Basic FA FB CA CB CR LB TC TCM1					
	BSCD	Basic FA LB TC TCM1					
Operating pressure	0.15~0.7MPa(22~1005psi)(1.5~7.0bar)						
Proof pressure	1.5MPa(215psi)(15bar)						
Temperature °C	-20~70						
Speed range mm/s	30~800						30~500
Stroke tolerance	0~250 ^{+1.0} ₀		251~1000 ^{+1.5} ₀		1001~1500 ^{+2.0} ₀		
Cushion type	Variable cushion						
Adjustable cushion stroke	21			28		29 28	
Port size [Note1]	Cylinder	1/8"	1/4"	3/8"		1/2"	
[Note1] Enclasp equipment	G1/8						
Unlocked Pressure	0.3~0.7MPa(45~100psi)(3~7bar)						
Static holding force (N)	600	900	1400	2200	3600	5500	8600

Symbol

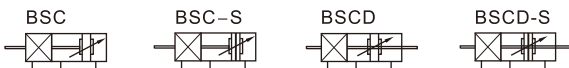

[Note1] PT thread, G thread and NPT thread are available.
Add) Refer to P337 for detail of sensor switch.

Product feature

1. Belong to SC series standard cylinder add lock structure.
2. Can be locked at random positions in stroke scope.
3. Reasonable lock structure, the lock state no relation with the direction of piston moving.

Stroke

Bore size (mm)	Standard stroke (mm)	Max.std stroke	Max. stroke
32	25 50 75 80 100 125 150 160 175 200 250 300 350 400 450 500	1000	2000
40	25 50 75 80 100 125 150 160 175 200 250 300 350 400 450 500 600 700 800	1200	2000
50	25 50 75 80 100 125 150 160 175 200 250 300 350 400 450 500 600 700 800 900 1000	1200	2000
63	25 50 75 80 100 125 150 160 175 200 250 300 350 400 450 500 600 700 800 900 1000	1500	2000
80	25 50 75 80 100 125 150 160 175 200 250 300 350 400 450 500 600 700 800 900 1000	1500	2000
100	25 50 75 80 100 125 150 160 175 200 250 300 350 400 450 500 600 700 800 900 1000	1500	2000
125	25 50 75 80 100 125 150 160 175 200 250 300 350 400 450 500 600 700 800 900 1000	1500	2000

[Note] Consult us for non-standard stroke.

Ordering code

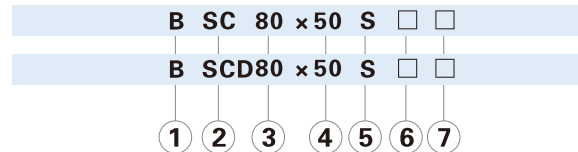

① Type	② Model	③ Bore size	④ Stroke	⑤ Magnet	⑥ Mounting type [Note1]	⑦ Thread type
B: Enclasp cylinder	SC: Double acting type	32 40 50 63 80 100 125	Refer to stroke table for details	Blank: Without magnet S: With magnet	Blank	Blank: PT G: G T: NPT
	SCD: Double rod type	Blank				
				LB		
				FA		
				FB		
				CA		
				CB		
				TC		
				Blank		
				LB		
				FA		
				FB		
				TC		

[Note1] Please refer to page 48~51 for accessory parts. TC is used with TCM1.

Standard cylinder(Tir-rod)

BSC Series—Enclasp type

Inner structure and material of major parts

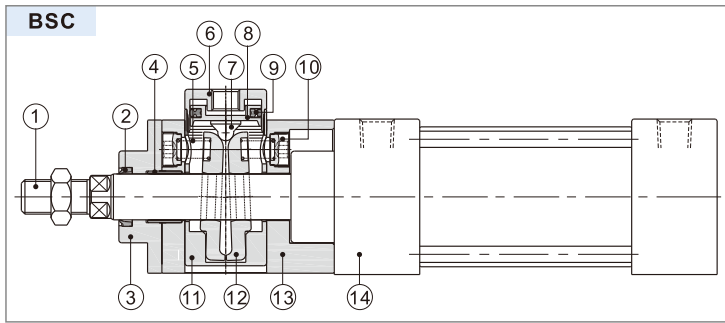

NO.	Item	Material
1	Piston rod	Carbon steel with 20μm chrome plated
2	Packing	Plastic
3	Packing holder	Aluminum alloy
4	Bearing	Carbon steel+Bronze sinter
5	Spring	Spring steel
6	Cover	Aluminum alloy
7	Unlocked header	Wear resistant material
8	Unlocked piston	Aluminum alloy
9	Piston O-ring	NBR
10	Screw	Carbon steel
11	Sleeve	Aluminum alloy
12	Clamp header	Aluminium bronze
13	Fixed holder	Aluminum alloy
14	SC series cylinder	-

Dimensions

BSC

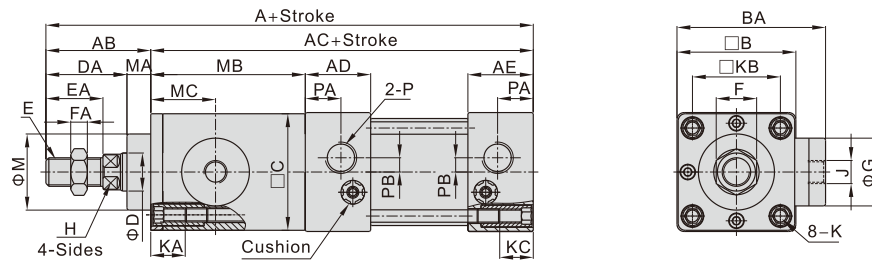

Bore size\Item	A	AB	AC	AD	AE	B	BA	C	D	DA	E	EA	F	FA	G	H	J	K	KA	KB	KC	M	MA	MB	MC	P	PA	PB
32	195	42	153	27.5	27.5	45	64	44	12	32	M10×1.25	22	17	6	30	10	G1/8	M6X1.0	14	33	14	28	10	60	25	1/8"	14	5.5
40	202	44	158	27.5	27.5	50	62.5	49	16	34	M12×1.25	24	17	7	28.5	13	G1/8	M6X1.0	14	37	14	32	10	65	27.5	1/4"	15	6
50	221	52	169	27.5	27.5	62	76.5	61	20	42	M16×1.5	32	23	8	35.5	17	G1/8	M6X1.0	14	47	14	38	10	76	33	1/4"	17	8.5
63	224	52	172	27.5	27.5	75	88	74	20	42	M16×1.5	32	23	8	44.5	17	G1/8	M8X1.25	14	56	14	38	10	76	33	3/8"	15	9.5
80	285	69	216	33	33	94	107	93	25	54	M20×1.5	40	26	10	55.5	22	G1/8	M10X1.5	16	70	16	47	15	109	47	3/8"	19.5	10
100	291	69	222	33	33	112	116	111	25	54	M20×1.5	40	26	10	55.5	22	G1/8	M10X1.5	16	84	16	47	15	109	47	1/2"	16.5	11
125	321	86	235	38	38	136	150	133	32	68	M27×2.0	54	41	13.5	70	27	G1/8	M12X1.75	21.5	104	21.5	52	18	120	63	1/2"	20	14

Remark: The dimensions of magnet type cylinder are the same as non-magnet type cylinder.

BSCD

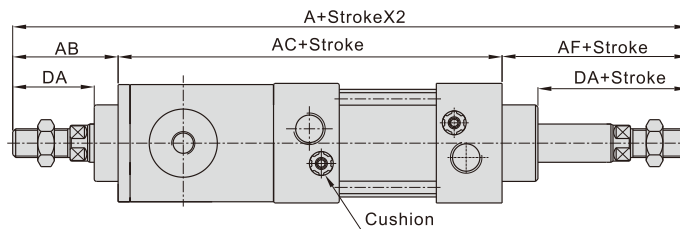

Bore size\Item	A	AB	AC	AF	DA	E	FA
32	242	42	153	47	32	M10×1.25	6
40	251	44	158	49	34	M12×1.25	7
50	278	52	169	57	42	M16×1.5	8
63	281	52	172	57	42	M16×1.5	8
80	360	69	216	75	54	M20×1.5	10
100	366	69	222	75	54	M20×1.5	10
125	409	86	235	88	68	M27×2	13.5

Remark:

1. The dimensions of magnet type cylinder are the same as non-magnet type cylinder.
2. The unmarked dimension is the same as BSC standard type.

Standard cylinder(Tir-rod)

SC Series—Accessories

List for ordering code of accessories

Accessories Bore size	Mounting accessories					
	LB	FA\FB	CA	CB	TC	TCM1
32	F-SC32LB	F-SC32FA	F-SC32CA	F-SC32CB	F-SC32TC	F-SI40TCM1
40	F-SC40LB	F-SC40FA	F-SC40CA	F-SC40CB	F-SC40TC	F-SC40TCM1
50	F-SC50LB	F-SC50FA	F-SC50CA	F-SC50CB	F-SC50TC	F-SC40TCM1
63	F-SC63LB	F-SC63FA	F-SC63CA	F-SC63CB	F-SC63TC	F-SC40TCM1
80	F-SC80LB	F-SC80FA	F-SC80CA	F-SC80CB	F-SC80TC	F-SC80TCM1
100	F-SC100LB	F-SC100FA	F-SC100CA	F-SC100CB	F-SC100TC	F-SC80TCM1
125	F-SC125LB	F-SC125FA	F-SC125CA	F-SC125CB	F-SC125TC	F-SC125TCM1
160	F-SC160LB	F-SC160FA	F-SC160CA	F-SC160CB	F-SC160TC	F-SC160TCM1
200	F-SC200LB	F-SC200FA	F-SC200CA	F-SC200CB	F-SC200TC	F-SC160TCM1
250	F-SC250LB	F-SC250FA	F-SC250CA	F-SC250CB	F-SC250TC	F-SC250TCM1

Accessories Bore size	Knuckle				Sensor switch	
	I: I Knuckle	Y: Y Knuckle	F: F Knuckle	U: U Knuckle	CMSG	DMSG(S)
32	F-M10X125I	F-M10X125Y	F-M10X125F	F-M10X125U	CMSG	DMSG(S)
40	F-M12X125I	F-M12X125Y	F-M12X125F	F-M12X125U		
50	F-M16X150I	F-M16X150Y	F-M16X150F	F-M16X150U		
63	F-M16X150I	F-M16X150Y	F-M16X150F	F-M16X150U		
80	F-M20X150I	F-M20X150Y	F-M20X150F	F-M20X150U		
100	F-M20X150I	F-M20X150Y	F-M20X150F	F-M20X150U		
125	F-M27X200I	F-M27X200Y	F-M27X200F	F-M27X200U		
160	F-M36X200I	F-M36X200Y	F-M36X200F	F-M36X200U		
200	F-M36X200I	F-M36X200Y	F-M36X200F	F-M36X200U		
250	F-M42X200Y	F-M42X200Y	-	-		

Accessory selection

Accessories Cylinder model	Mounting accessories							Knuckle [Note1]				Sensor switch	
	LB	FA	FB	CA	CB	TC	TCM1	I	Y	U	F	CMSG	DMSG(S)
SC	Standard	●	●	●	●	●	●	●	●	●	●	×	×
	With magnet	●	●	●	●	●	●	●	●	●	●	●	●
BSC	Standard	●	●	●	●	●	●	●	●	●	●	×	×
	With magnet	●	●	●	●	●	●	●	●	●	●	●	●
SCD	Standard	●	●	×	×	×	●	●	●	●	●	×	×
	With magnet	●	●	×	×	×	●	●	●	●	●	●	●
BSCD	Standard	●	●	×	×	×	●	●	●	●	●	×	×
	With magnet	●	●	×	×	×	●	●	●	●	●	●	●
SCJ	Standard	●	●	×	×	×	●	●	●	●	●	×	×
	With magnet	●	●	×	×	×	●	●	●	●	●	●	●
SCT	Standard	●	●	●	●	●	●	●	●	●	●	×	×
	With magnet	●	●	●	●	●	●	●	●	●	●	●	●
SCL	Standard	●	●	●	●	●	●	●	●	●	●	×	×
	With magnet	●	●	●	●	●	●	●	●	●	●	●	●
SCF	Standard	●	●	●	●	●	●	●	●	●	●	×	×
	With magnet	●	●	●	●	●	●	●	●	●	●	●	●

[Note1] Please refer to P333~336 for knuckle detail.

Material of accessories

Accessories Bore size	Mounting accessories							Knuckle			
	LB	FA	FB	CA	CB	TC	TCM1	I	Y	F	U
32~100	□	●	●	◇	◇	◇	◇	□	□	□	□
125~200	◇	◇	◇	◇	◇	◇	◇	□	□	-	□
250	◇	■	■	◇	◇	◇	◇	■	■	-	-

●—Aluminum alloy, ■—Cast steel, ◇—Nodular cast iron, □—Carbon steel.

Standard cylinder(Tir-rod)

SC Series—Accessories

Dimensions

LB

Φ32~Φ100

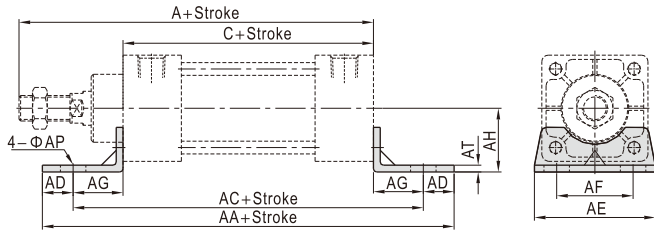

CA

Φ32~Φ100

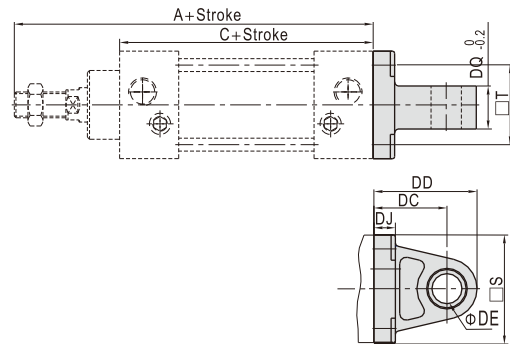

Φ125~Φ250

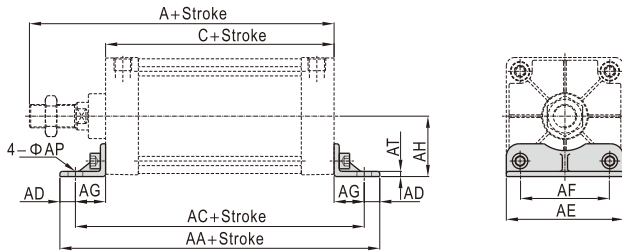

Φ125~Φ250

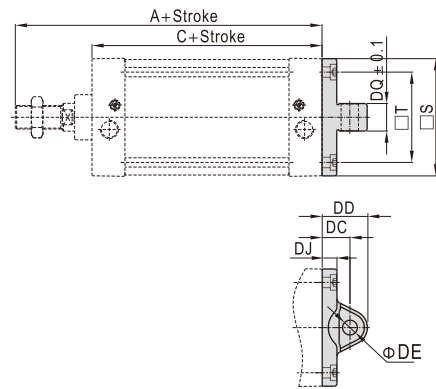

Bore size\Item	A	C	AA	AC	AD	AE	AF	AG	AH	AP	AT
32	140	93	153	134	9.5	50	33	20.5	28	9	3
40	142	93	169	140	14.5	57	36	23.5	30	12	3
50	150	93	173	149	12	68	47	28	36.5	12	3
63	153	96	184	158	13	80	56	31	41	12	3
80	182	107	199	167	16	97	70	30	49	14	4
100	188	113	209	173	18	112	84	30	57	14	4
125	203	115	221	185	18	136	104	35	70	17	6
160	239	126	246	206	20	174	134	40	91	17	8
200	244	126	276	226	25	214	163	50	113.5	22	9
250	294	153	323	273	25	267	201	60	141	26	15

Bore size\Item	A	C	DC	DD	DE	DJ	DQ	S	T
32	140	93	34	44.5	12	9	16	45	33
40	142	93	34	45.5	14	9	20	49	37
50	150	93	34	46	14	10	20	61	47
63	153	96	34	46.5	14	10	20	74	56
80	182	107	48	64.5	20	14	32	93	70
100	188	113	48	65	20	14	32	111	84
125	203	115	32	52	20	17	31.7	135	104
160	239	126	40	68	28	19.5	39.7	173	134
200	244	126	60	90	28	23	39.7	213	163
250	294	153	70	106	36	24	49.7	255	202

Standard cylinder(Tir-rod)

SC Series—Accessories

FA/FB

Φ32~Φ100

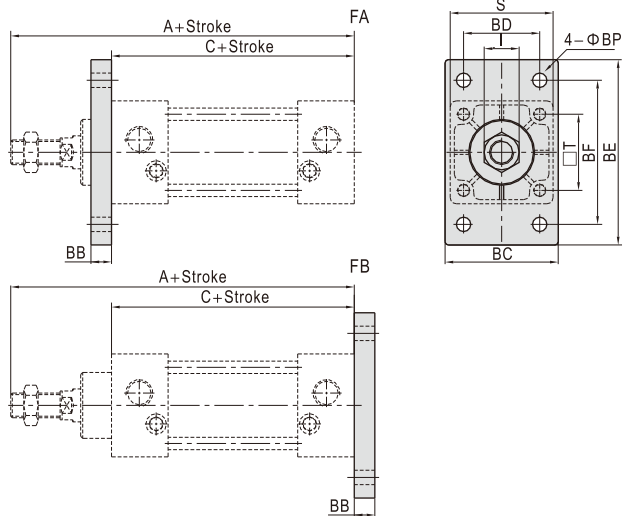

CB

Φ32~Φ100

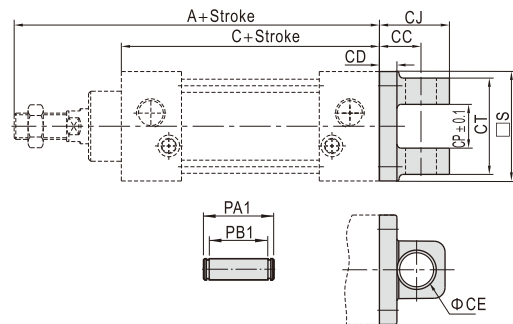

Φ125~Φ250

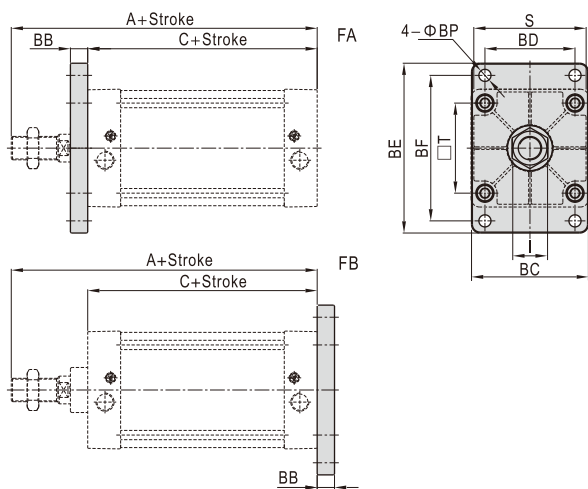

Φ125~Φ250

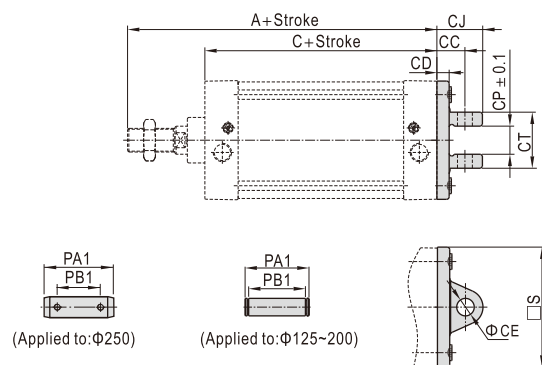

Bore size\Item	A	C	BB	BC	BD	BE	BF	BP	I	S	T
32	140	93	10	47	33	80	58	7	17	45	33
40	142	93	10	53	36	90	70	7	17	50	37
50	150	93	10	65	47	104	86	9	23	62	47
63	153	96	12	75	56	118	98	9	23	75	56
80	182	107	16	95	70	140	119	11	26	94	70
100	188	113	16	115	84	160	138	11	26	112	84
125	203	115	20	135	104	196	168	14	41	136	104
160	239	126	20	173	134	248	212	18	55	174	134
200	244	126	25	213	163	286	250	18	55	214	163
250	294	153	25	255	201	356	312	22	65	267	202

Bore size\Item	A	C	S	CC	CD	CE	CJ	CP	CT	PA1	PB1
32	140	93	45	19	9	12	29.5	16.3	32	39	32.8
40	142	93	49	19	9	14	30.5	20.3	44	51	44.8
50	150	93	61	19	10	14	31	20.3	52	59	52.8
63	153	96	74	19	10	14	31.5	20.3	52	59	52.8
80	182	107	93	32	14	20	48.5	32.3	64	73	64.8
100	188	113	111	32	14	20	49	32.3	64	73	64.8
125	203	115	135	32	14	20	52	32.1	64	73	64.8
160	239	126	173	40	15	28	68	40.1	80	90.2	80.8
200	244	126	213	60	23	28	90	40.1	80	90.2	80.8
250	294	153	255	70	24	36	106	50.1	100	130	108

Standard cylinder(Tir-rod)

SC Series—Accessories

TC

Φ32~Φ100

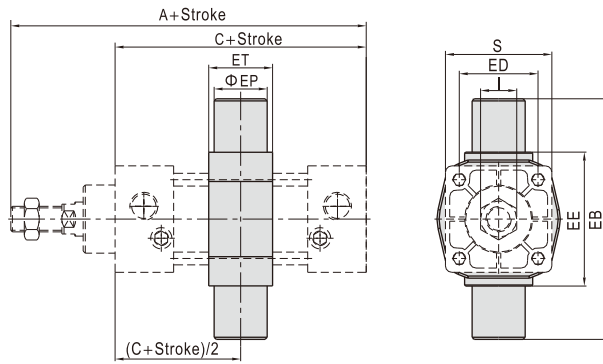

TCM1

Φ32~Φ100

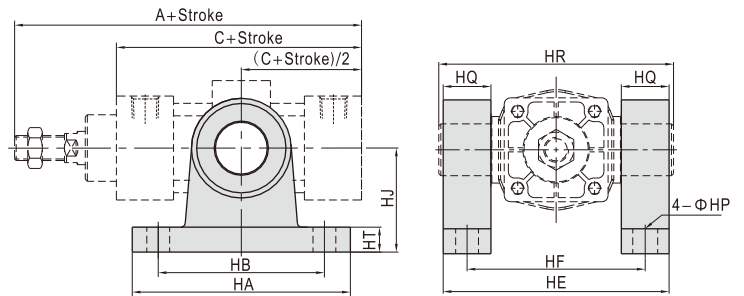

Φ125~Φ250

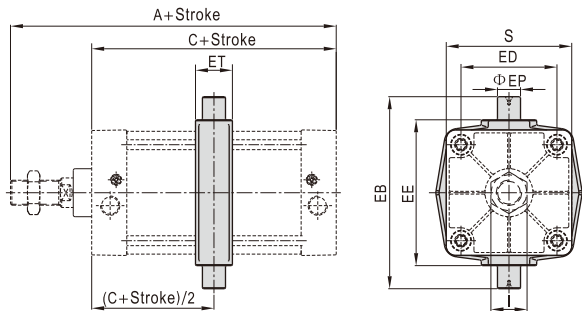

Φ125~Φ250

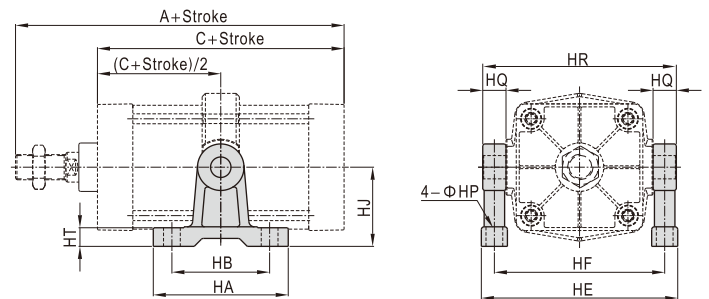

Bore size\Item	A	C	EB	ED	EE	EP	ET	I	S
32	140	93	87	33	55	16	22	17	45
40	142	93	113	37	63	25	28	17	50
50	150	93	126	47	76	25	28	23	62
63	153	96	138	56	88	25	30	23	75
80	182	107	164	70	114	25	32	26	94
100	188	113	182	84	132	25	38	26	112
125	203	115	208	104	158	25	40	41	136
160	239	126	272	134	200	36	46	55	174
200	244	126	318	163	246	36	46	55	214
250	294	153	394	202	304	45	56	65	267

[Note] The installation position of the accessories can not be adjusted arbitrarily.

Bore size\Item	A	C	HA	HB	HE	HF	HP	HQ	HR	HT	HJ
32	140	93	100	75	90	71	12	16	87	11	54
40	142	93	103	80	109	86	11	23	113	12	50
50	150	93	103	80	122	99	11	23	126	12	50
63	153	96	103	80	134	111	11	23	138	12	50
80	182	107	110	85	160	137	13	23	164	12	70
100	188	113	110	85	178	155	13	23	182	12	70
125	203	115	145	105	211	183	18	25	208	20	85
160	239	126	185	140	272	236	22	36	272	25	130
200	244	126	185	140	318	282	22	36	318	25	130
250	294	153	215	165	394	349	26	45	394	28	160

[Note] The installation position of the accessories can not be adjusted arbitrarily.